

CNC precision turning machine for simultaneous machining on main and counter spindle



Technical data:

Tool turret

VDI 25 – 12 positions
optional 16 or 48 positions
with individual drive 6.000 rpm

Bar capacity

Main spindle 16/26/32/42 mm

Spindle speed

Main spindle and counter spindle up to 15.000 rpm

Control system

SIEMENS / Fanuc

Dimensions L x W x H

Approx. 2,95 x 1,95 x 1,95 m

Machine variants:

B2

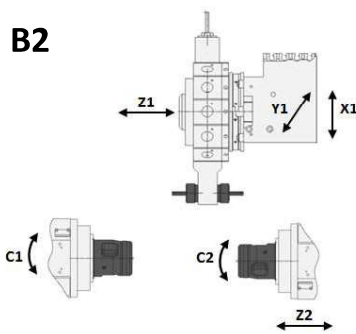

B6

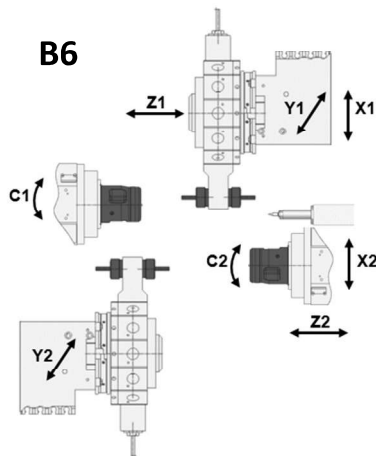

B10

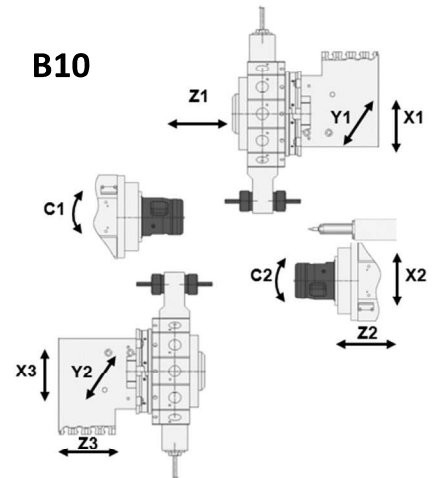

- Feeding by a robot via a loading shuttle
- Loading and unloading via the integrated feeding system
- Discharging via an unloading shuttle to the robot